

Pass Management Module of Temperature Measurement & Face Recognition Manual



Model: YXD-F8

It can be used with access gates and attendance for communities, office buildings, schools, hotels, scenic spots, transportation hubs and other public service places.

Parameters

Camera	Resolution	2 million pixels
	Type	Binocular wide dynamic camera
	Aperture	F2.4
	Focusing distance	50-150cm
	White balance	auto
Photofloodlight	LED and IR dual photo flood light	
	Size	8.0 inch IPS LCD screen
Screen	Resolution	800×1280
	Touch	Not supported (optional support)
Processor	CPU	RK3288 quad-core (optional RK3399 six-core, MSM8953 eight-core)
	Storage	EMMC 8G
Network module	Ethernet and wireless (WIFI)	
	Audio	2.5W / 4R speakers
USB	1 USB OTG, 1 USB HOST standard A port	
	Serial communication	1 RS232 serial port
Relay output	1 door open signal output	
	Wiegand	One Wiegand 26/34 output, one Wiegand 26/34 input
Upgrade button	Support Uboot upgrade button	
Wired network	1 RJ45 Ethernet socket	

Credit card reader	None (optional IC card reader, ID card, ID card)	
	Face Detection	Supports detection and tracking of multiple people at the same time
Face library	Up to 30,000	
1: N face recognition	Support	
	1: 1 face comparison	Support
Stranger detection		Support
Identify distance configuration	Support	
UI interface configuration	Support	
Upgrade remotely	Support	
Interface	Interfaces include device management, personnel / photo management, record query, etc.	
Deployment method	Support public cloud deployment, privatized deployment, LAN use, stand-alone use	
Temperature detection	Support	
	Temperature detection distance	1 meter (optimal distance 0.5 meter)
Temperature measurement accuracy	≤ ±0.5°C	
Temperature measurement range	10°C~42°C	
Pixels	32 X 32 dots (total 1024 pixels)	
Visitors' temperature is normal and released directly	Support	
Abnormal temperature alarm	Support (temperature alarm value can be set)	
Power	DC12V (±10%)	
	Operating temperature	0°C~40°C

General parameters	Storage temperature	-20°C~60°C
	Power consumption	13.5W (Max)
	Installation method	Screwed by wall mount bracket
	Size	Standard: 274.24*128*21.48 (mm)
IC card / ID card: 296.18*132.88*25 (mm)		
Packing list	Machine * 1, power adapter * 1, manual * 1, certificate of conformity * 1	

Installation Notes

1. Module structure description



Optional credit card (ID) version, size: 296.18*132.88*25 (mm)

2. Port description

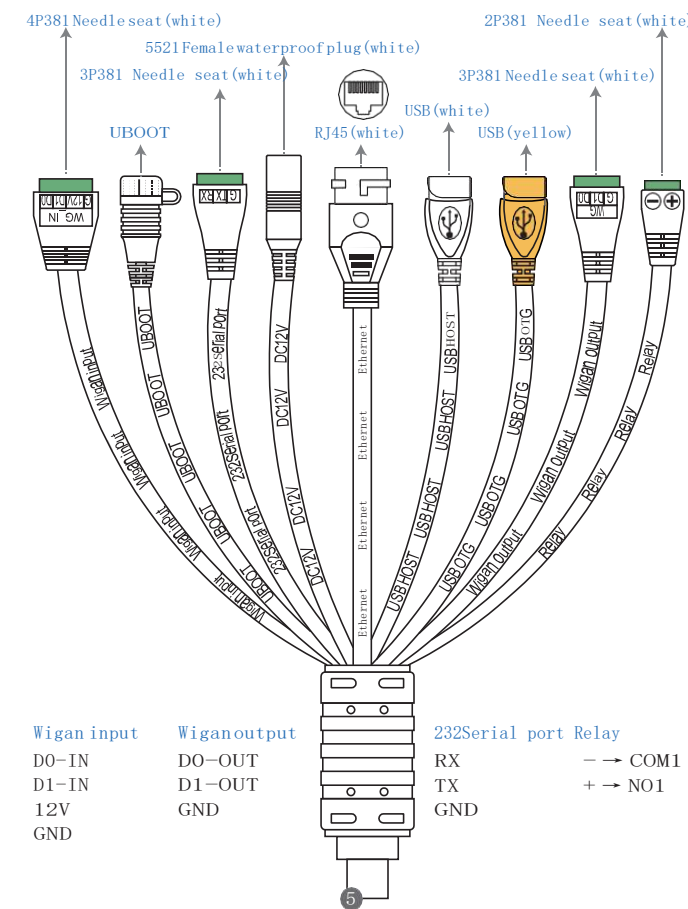

3、Installation method (take SW-1081D as an example)

- ① Mark the 4 fixing holes of the wall mount bracket on the pre-installed wall.
Drill the holes and fix the plastic expansion bolts in the positioning holes on the wall at one time.

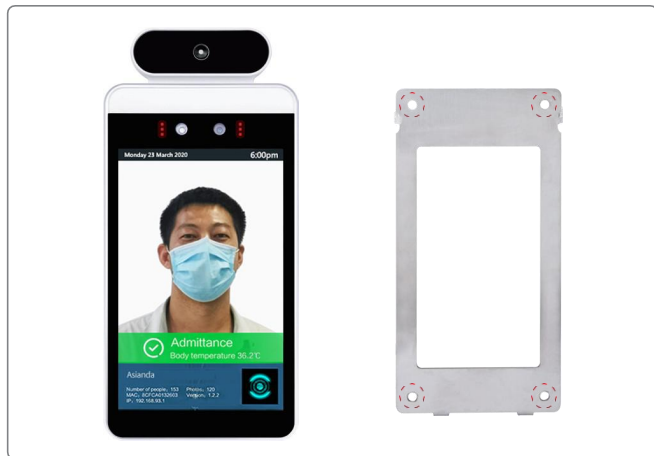

Note: The wall-mounted fixing plate is recommended to be 1.35 meters from the ground.

- ② Fix the wall mount bracket on the wall with 4 countersunk head tapping screws.



- ③ Fix the module on the hook of the wall mount bracket, and fix the lower hole of the device with the combination screw below.



Care and Maintenance

1. During the installation and use of the product, all electrical safety regulations must be strictly observed.
2. Please use the power adapter provided by the regular manufacturer. For specific requirements of the power adapter, see the product parameter table.
3. When installing on the gate, please make sure that the product is installed firmly.
4. If the product does not work properly, please contact the after-sales service personnel. Do not disassemble or modify the product in any way. (The company does not assume any responsibility for problems caused by unauthorized modification or repair.)
5. Do not immerse the product in water. When the product is installed outdoors, try to use it with the rain cover provided by our company.
6. Please understand that you are responsible for properly configuring all passwords and other related product security settings, and keeping your username and password properly.
7. If the equipment does not work properly, please do not disassemble it for repair, otherwise it will affect the equipment warranty.
8. Avoid extreme or extreme environments such as extreme high temperature (or low temperature), high humidity, vibration, radiation, and chemical corrosion during installation and use.

Warranty Card

Dear customer, thank you for purchasing the Face Recognition Pass Management Module. In order to better serve you, please read, fill in and properly keep the warranty card after purchasing the product.

Your name	
Contact person	
Telephone	
Address	
Date of purchase	
Serial number	
Maintenance records	
Cause of issue	

Warranty description:

1. This warranty card is required to be properly kept by the user as a proof of repair.
2. This product is guaranteed for one year from the date of purchase.
3. Warranty Equipment During the warranty period, under normal use and maintenance conditions, the machine itself malfunctions. Upon inspection, the company will provide free repair and parts replacement.
4. During the warranty period, if the following events occur, the company has the right to refuse service or charge materials and maintenance service fees as appropriate.
 - 1) This warranty card and valid proof of purchase cannot be provided.
 - 2) Product failure and damage caused by improper user use.
 - 3) Damage due to abnormal external forces.
 - 4) It is not our maintenance service, and the user dismantles it to cause damage.
 - 5) Failures and damage caused by natural disasters or other force majeure factors.
 - 6) Others intentionally damaged.
5. The company reserves the right to modify and interpret all content.